

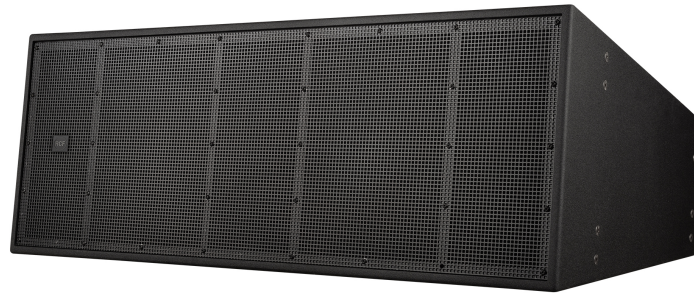

HVL 15-L

LONG THROW THREE-WAY SYSTEM



Description

HVL 15-L is a three-way, bi-amp loudspeaker system for long-throw applications, outfitted with 2 x 15" woofers, 2 x 10" midranges, and 2 x 4.0" voice coil, titanium dome compression drivers. Equipped with the latest generation of RCF precision transducers with powerful neodymium magnets, HVL 15-L provides very high output and accurate sound and voice reproduction. The system, driven in bi-amped mode, can produce a max SPL of 144 dB, handling 1000 W RMS (LF) + 900 W RMS (MHF). An internal passive filter provides crossover and equalization between the midranges and the compression drivers. The horizontal coverage is 90°, and the vertical coverage is 30°. A heavy-duty, weatherproof barrier strip provides connections. The cabinet is made of Baltic birch plywood. The finishing is a waterproof, textured, polyurea coating. The grille is in epoxy coated heavy-duty steel with open-cell fibers and water repellent woven-fabric backing.

Features

- › 1000 W (LF) + 900 W (MHF) power handling
- › 147 dB max SPL
- › 43 ÷ 18000 Hz frequency range
- › 90° x 30° coverage angles
- › Fully equipped with neodymium transducers
- › Bi-amped system with passive filter between MF and HF
- › Horn Loaded symmetric design
- › Baltic birch plywood cabinet and steel grille
- › Weatherproof treatment

Part Number

13000640 HVL 15-L W

White - RAL 9010 EAN 8024530017606



HVL 15-L

LONG THROW THREE-WAY SYSTEM

Line Art 2D

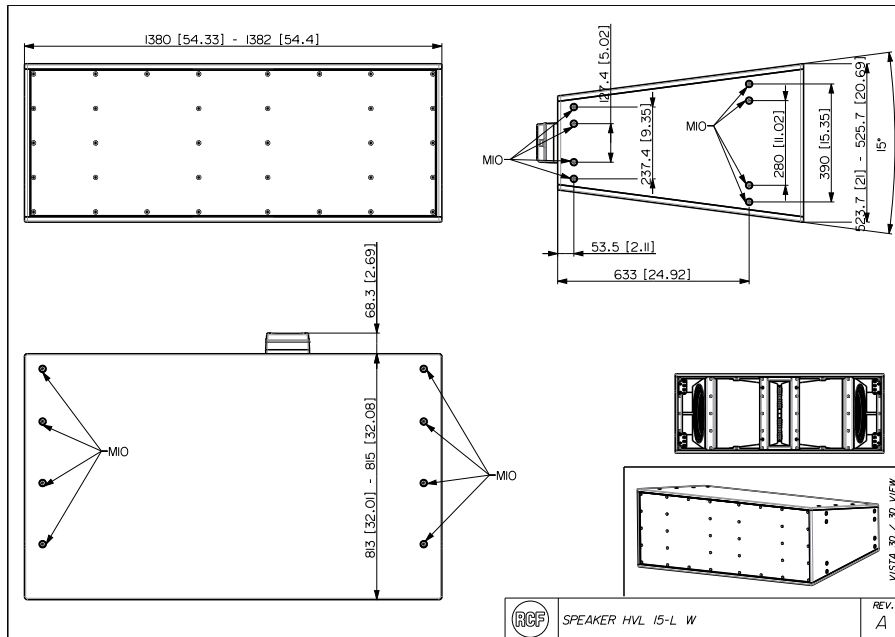

TECHNICAL SPECIFICATIONS

Acoustical specifications

Frequency Response (-10dB)	43 Hz - 18000 Hz
Frequency Response (-3dB)	59 Hz - 13000 Hz
Max SPL @ 1m	147 dB
Horizontal coverage angle	90°
Vertical coverage angle	30°
Directivity index Q	12

Power section

Amplification	Bi-Amp
Nominal Impedance LF	8 ohm
Power Handling LF	1000 W
Peak Power Handling LF	4000 W
Sensitivity LF	97 dB
Nominal Impedance MF+HF	8 ohm
Power Handling MF+HF	900 W
Peak Power Handling MF+HF	3600 W
Sensitivity MF + HF	111 dB
Protections MF+HF	Dynamic Active Mosfet
Crossover Frequencies	1000 Hz
Recommended Amplifiers	XPS 16K, XPS 16KD, QPS 10K

Transducers

Compression Driver	2 x 1.4" neo, 4.0" v.c
Midrange	2 x 10" neo, 3.0" v.c
Woofer	2 x 15" neo, 3.5" v.c

Input/Output section

Input connectors	Screw Terminals
Output connectors	Screw Terminals

Standard compliance

Safety agency	CE compliant
---------------	--------------



HVL 15-L

LONG THROW THREE-WAY SYSTEM

Physical specifications	Cabinet/Case Material	Baltic birch plywood
	Hardware	n° 8 x M20 on each side panel n° 8 x M20 on top and bottom panels
Size / Weight	Grille	Steel
	Color	White - RAL 9010, Black - RAL 9005
	Height	525 mm / 20.67 inches
	Width	1382 mm / 54.41 inches
	Depth	815 mm / 32.09 inches
	Weight	110 kg / 242.51 lbs