

V-BR TT 10

STAFFA VERTICALE



CARATTERISTICHE

- INSTALLAZIONE DEL DIFFUSORE SICURA E VELOCE
- INCLINAZIONE REGOLABILE
- VERNICIATURA NERA, RESISTENTE E ANTIGRAFFIO
- COSTRUZIONE IN ACCIAIO

SPECIFICHE TECNICHE

Specifiche generali	Pieces	1
Conformità agli standard	Marchio CE:	Yes
Specifiche fisiche	Materiale Cabinet/Case: Colore:	Metal Black
Dimensioni	Peso:	1.6 kg / 3.53 lbs
Informazioni di spedizione	Altezza imballaggio: Larghezza imballaggio: Profondità imballaggio: Peso imballaggio:	60 mm / 2.36 inches 350 mm / 13.78 inches 340 mm / 13.39 inches 2.1 kg / 4.63 lbs

CODICE

- **13360401**
V-BR TT 10

EAN 8024530016302

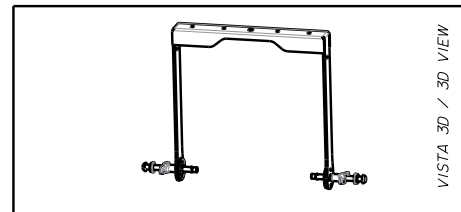
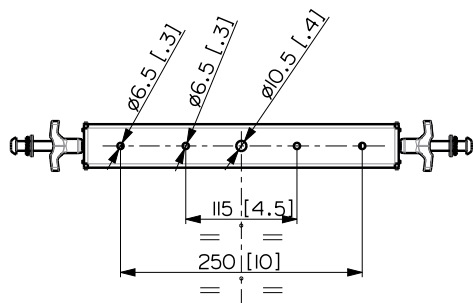
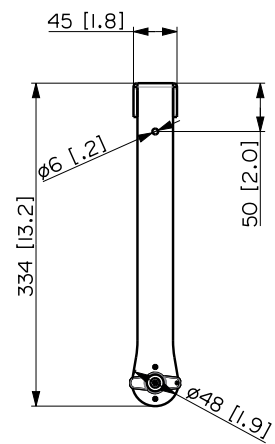
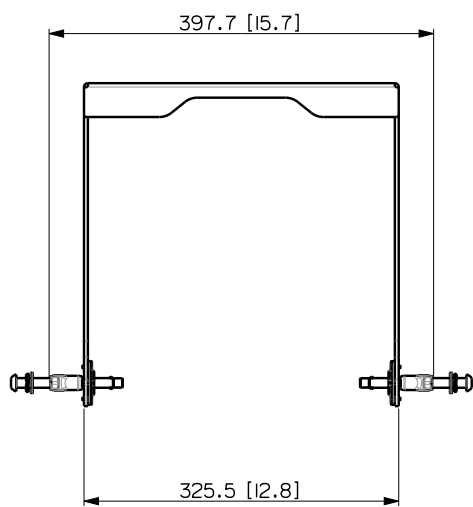

VISTA 3D / 3D VIEW

	VERTICAL BRACKET V-BR TT 10	REV. A
--	-----------------------------	-----------