

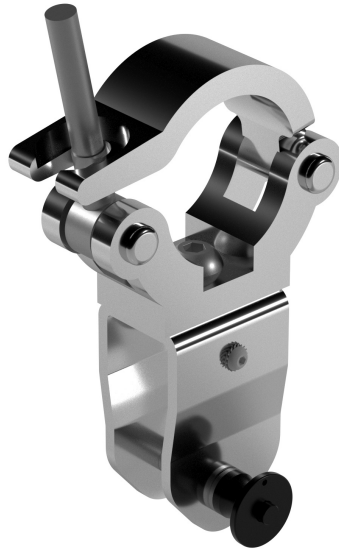

# CL-BR HDL 6

CLAMP BRACKET



**Description** Clamp Bracket for HDL 6-A, HDL 26-A, HL 6 and HL 35-S.

**Standard compliance** Safety agency CE compliant  
**Size / Weight** Weight 0.6 kg / 1.32 lbs

Line Art 2D

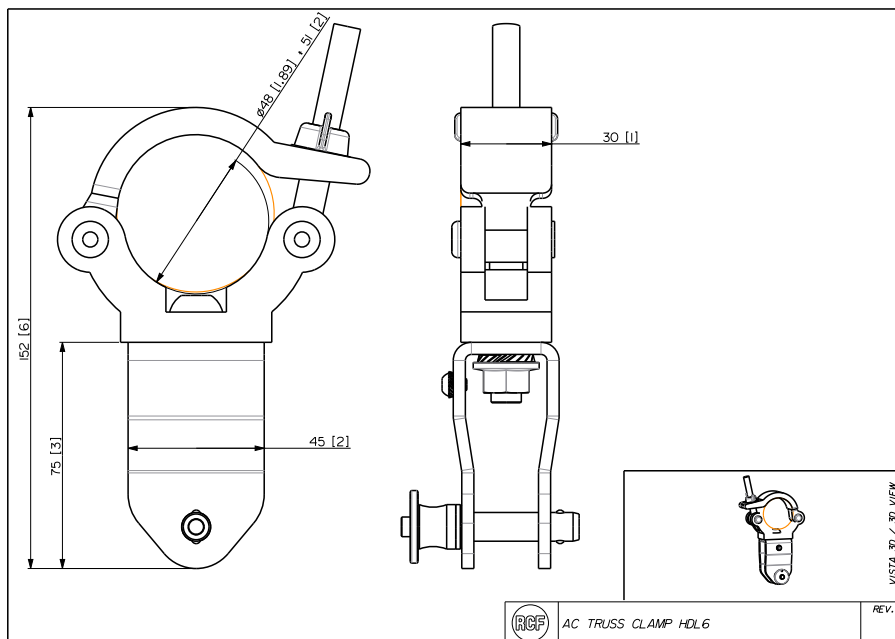

**Part Number** 13360371 CL-BR HDL 6

EAN 8024530014360

**Technical Specifications**

Products are continually improved. All specifications are therefore subject to change without notice.