



CMR 50T

TWO-WAY CEILING MONITOR SPEAKER



Description CMR 50T is a multipurpose two-way in-ceiling speaker, suitable for a wide range of applications. Thanks to its elegant and discreet design and accurate details, CMR 50T pairs any building's aesthetic. The high-quality transducers, aligned in a coaxial configuration, guarantees a precise music reproduction of the entire frequency band and provides impressive sound pressure levels for such a compact enclosure. Installation is easy with three long travel clamps. The magnetic grille allows immediate access to the power selector on the front shell: the line transformer provides 40W full power on 70V and 100V constant voltage lines, and five different power levels.

- Features**
- › 40W RMS power handling
 - › 110 dB max SPL
 - › 80 ÷ 20000 Hz frequency range
 - › 130° constant directivity conical coverage angle
 - › 5" high power woofer
 - › 1" neodymium dome tweeter
 - › Self-extinguishing plastic cabinet and metal backcan
 - › Steel magnetic front grille
 - › 4 pole EUROBLOCK connector (audio input and parallel link output)
 - › 5 different power levels selectable

Part Number 13100044 CMR 50T W

White - RAL 9003 EAN 8024530017439



CMR 50T

TWO-WAY CEILING MONITOR SPEAKER

Line Art 2D

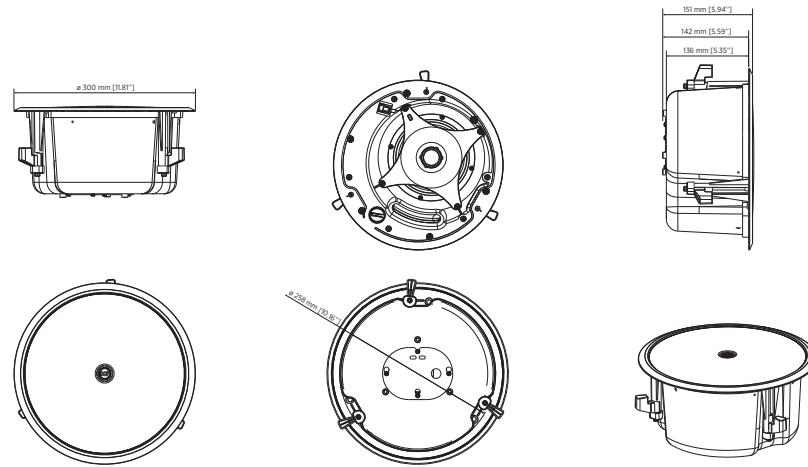

TECHNICAL SPECIFICATIONS

Acoustical specifications	Frequency Response (-10dB)	80 Hz ÷ 20000 Hz	
	Max SPL @ 1m	110 dB	
	Coverage angle	130°	
	System Sensitivity	88 dB	
Power section	Amplification	Full Range	
	Nominal Impedance	8 ohm	
	Power Handling	40 W RMS	
	Peak Power Handling	160 W PEAK	
	Crossover Frequencies	2500	
	Recommended Amplifiers	DMA 504, DMA 162, DMA 82, DMA 162P	
Transducers	Dome Tweeter	1 x 1.0" neo, 1.0" v.c	
	Woofer	1 x 5.0", 1.0" v.c	
Input/Output section	Input connectors	Euroblock	
	Output connectors	Euroblock	
	Constant Voltage Transformer	70/100 V	
	Power selection 1	40 W - 250 ohm	
	Power selection 2	20 W - 500 ohm	
	Power selection 3	10 W - 1000 ohm	
Standard compliance	Power selection 4	5 W - 2000 ohm	
	Power selection 5	2.5 W - 4000 ohm	
	Safety agency	CE compliant, UL 1480A	
	Physical specifications	Cabinet/Case Material	ABS
		Hardware	Steel backcan
Grille		Steel	
Color		White - RAL 9003	
Size / Weight	Depth	151 mm / 5.94 inches	
	Recessed Depth	142 mm / 5.59 inches	
	Diameter	300 mm / 11.81 inches	
	Cut out diameter	260 mm / 10.24 inches	
	Weight	4 kg / 8.82 lbs	



CMR 50T

TWO-WAY CEILING MONITOR SPEAKER

Rigging / Mounting

ACCESSORIES

13360492 GRILLE KIT 4X CMR B

Black - RAL 9005 EAN 8024530019402

FLYING BRACKETS

13360490 MUD RING 4X CMR

EAN 8024530019396

13360489 TILE BRIDGE 4X CMR

EAN 8024530019389